

CONNECTION INSTRUCTIONS #1

Differential Line Driver

Encoder signals from 5 VDC to 24 VDC (must specify the voltage when ordering)

This is the preferred type of encoder output as it has the best noise immunity. Connect each encoder signal to its like optical isolator input (A to A, A/ to A/, etc).

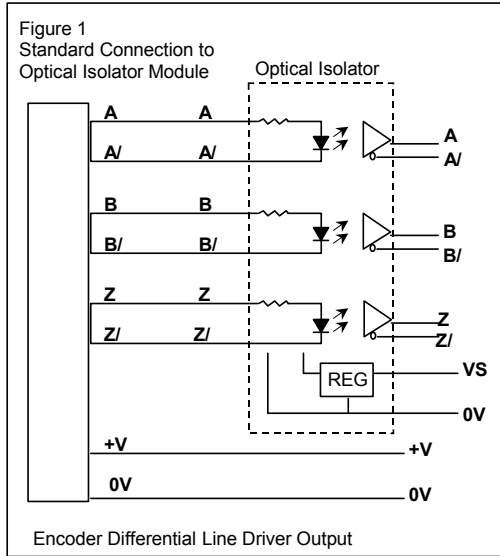
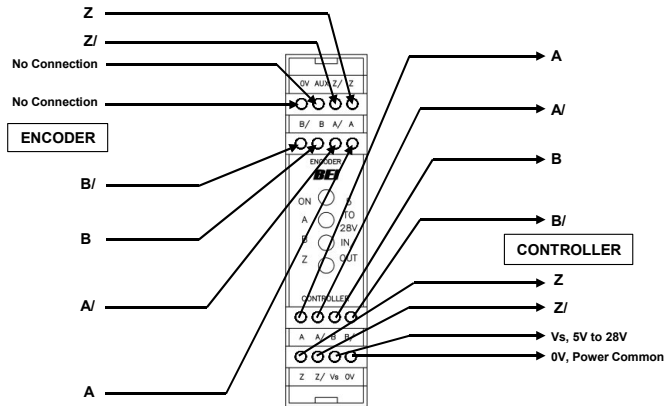

CONNECTION INSTRUCTIONS #2

Single Ended Line Driver

Encoder signal from 5 VDC to 24 VDC (must specify the voltage when ordering)

Connect encoder output A to optical isolator module input channel A, B to B and Z to Z. Connect the A/, B/, and Z/ inputs of the optical isolator to circuit common of the encoder supply. Single ended operation is limited to shorter cable runs and is more susceptible to noise.

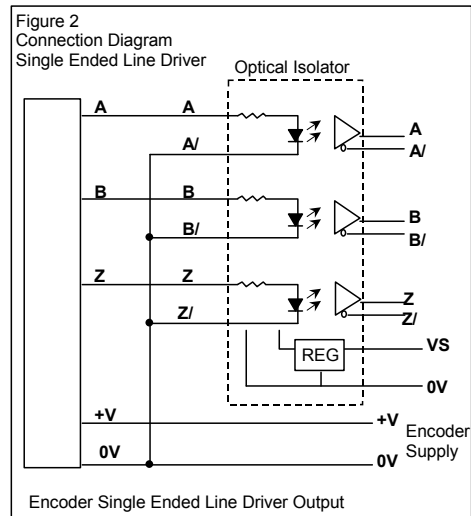
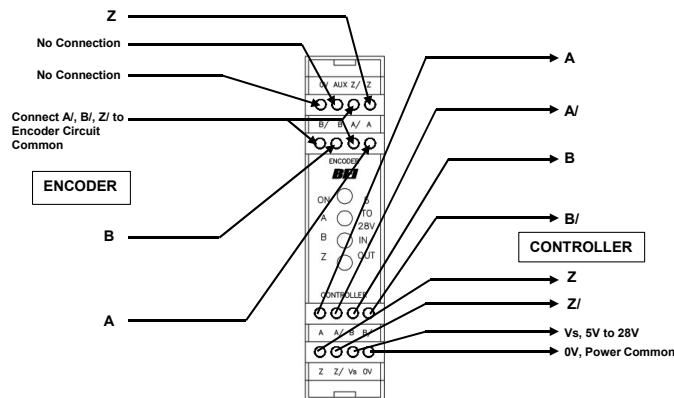

CONNECTION INSTRUCTIONS #3

Open Collector with or without Internal Pull-up Resistors

Encoder NPN (sinking) outputs.

Connect encoder output A to optical isolator module input A/, B to B/ and Z to Z/. Connect the A, B, and Z inputs of the optical isolator to the auxiliary output terminal on the optical isolator module for 5V module and to higher voltage when specified by module model and part number. This connection results in a logic inversion within the optical isolator module. To compensate for the logic reversal, swap A for A/, B for B/, and Z for Z/ at the optical isolator outputs.

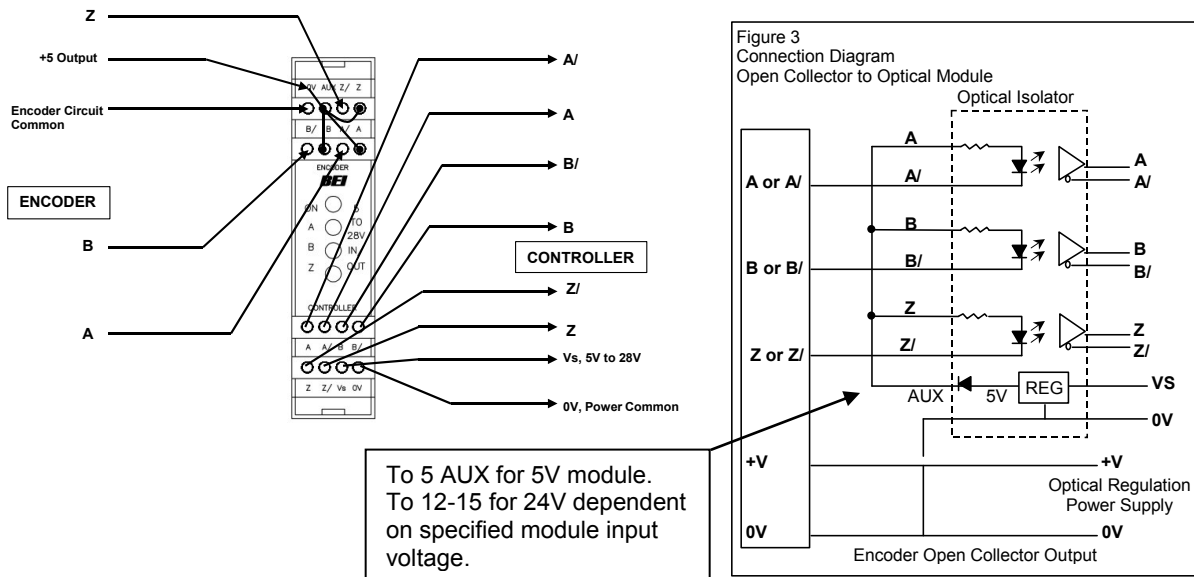

Uses for Optical Isolator Module

Example 1: Resolve an electrical conflict between encoder output and receiving electronics

Sometimes system constraints result in an incompatibility between the encoder output and the receiving electronics or the cabling. A typical symptom of this problem is missed or intermittent counts. As an example, a single-ended TTL receiver that is more than 20 feet from the encoder may not be able to compensate for the signal attenuation and ringing caused by the encoder cabling. An optical isolator module installed near the receiver as shown in Figure 4 can receive the signal, rejecting the cable effects and produce a signal compatible with the input device.

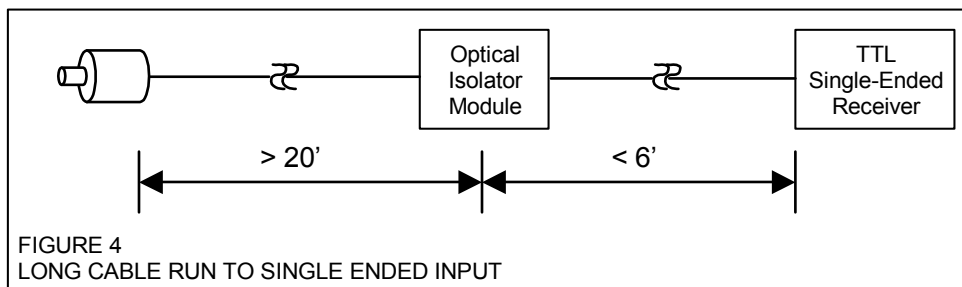

Example 2: Signal Splitter

The optical isolator can be used to connect a single encoder to multiple devices. Optical isolator can be used to split an encoder output to drive up to 8 devices as shown in Figure 5. One optical isolator module is used to drive each receiver. Optical isolator modules can be specified with outputs to match receiver inputs; i.e. an encoder signal can be split to drive a differential TTL input with one module, a 12 V line driver with another module and provide an open collector, NPN signal with another module.

** Also see the BEI Encoder Signal Broadcaster Module on page 5 for this application**

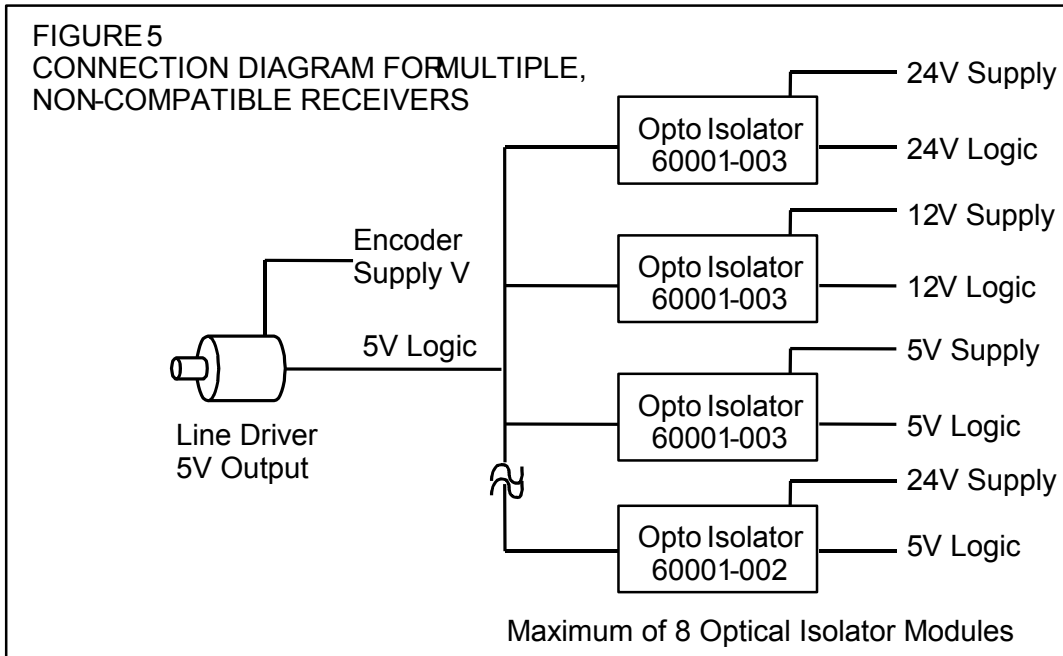

Example 3: Repeater

On extremely long cable runs (greater than 500 feet), an optical isolator module may be needed as a mid-point repeater to receive, amplify and re-broadcast the signal. An example is illustrated in Figure 6.

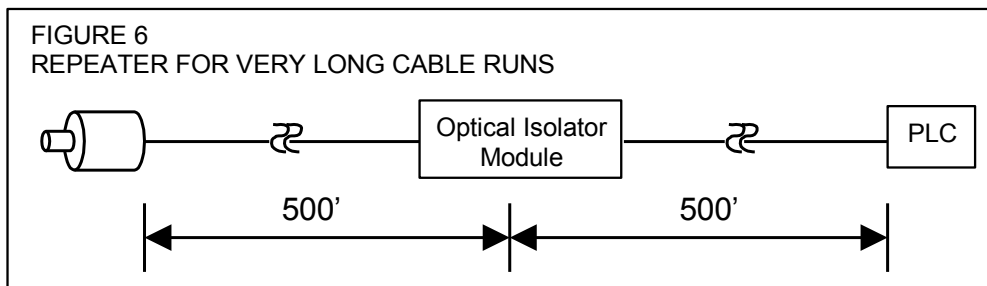

Optical Isolator Selection Table

To find the correct optical isolator for your application, look in column 1 for the logic voltage of your encoder. Then choose the correct row in column 2 that describes the type of output from the isolator that is compatible with your receiving electronics. Read across to columns 3 and 4 to find the module and part number of the correct optical isolator.

| (1) Encoder Output Logic Level Voltage | (2) Optical Isolator Output Logic Level Voltage | (3) Model Number | (4) Part Number |
|---|--|------------------------|--------------------|
| 5V | Vout = Vin | EM-DR1-IC-5-TB-28V/V | 60001-003 |
| | Vout = 5V | EM-DR1-IC-5-TB-28V/5 | 60001-002 |
| | Vout = OC | EM-DR1-IC-5-TB-28V/OC | 60001-004 |
| 12-15V | Vout = Vin | EM-DR1-IC-15-TB-28V/V | 60001-008 |
| | Vout = 5V | EM-DR1-IC-15-TB-28V/5 | 60001-012 |
| | Vout = OC | EM-DR1-IC-15-TB-28V/OC | 60001-014 |
| 24V | Vout = Vin | EM-DR1-IC-24-TB-28V/V | 60001-010 |
| | Vout = 5V | EM-DR1-IC-24-TB-28V/5 | 60001-011 |
| | Vout = OC | EM-DR1-IC-24-TB-28V/OC | 60001-013 |

Additional Modules and Accessories

ENCODER SIGNAL BROADCASTER MODULE

Accepts standard incremental encoder inputs and can broadcast up to four encoder signals to four independent devices. Each of the broadcast signals are optically isolated eliminating ground loops.



POWER SUPPLY

With a wide range of acceptable input voltages (AC and DC) this DIN Rail mountable power supply is usable in virtually all industrial applications worldwide. It has built in surge protection to reduce faults due to transients and it has 100% reserve capacity for startup and overload conditions.



CABLE AND CABLE ASSEMBLIES

Cable reels for your own custom wiring requirements or cable assemblies are available, using high quality custom BEI standard cable consisting of four, low capacitance shielded twisted pairs with an overall shield, extra large conductors for power, and signal ground; all within an abrasion-resistant PVC jacket.



Cable Reels

100 ft. reel Part No. 37048-003-100
500 ft. reel Part No. 37048-003-500

Cable Assemblies

Part Nos. for MS3106F14S-6S Mating Connector

10 ft. # 31186-1410 | 20 ft. # 31186-1420 | 30ft. # 31186-1430

Part Nos. for MS3106F16S-1S Mating Connector

10 ft. # 31186-1610 | 20 ft. # 31186-1620 | 30ft. # 31186-1630

Part Nos. for MS3106F18S-1S Mating Connector

10 ft. # 31186-1810 | 20 ft. # 31186-1820 | 30ft. # 31186-1830

